



4 Break Time



Lesson 1 Vocabulary

1 Dopasuj zabawy do zdań. Odegraj scenkę z kolegą lub koleżanką.

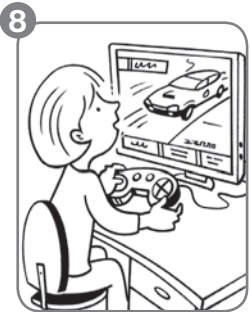
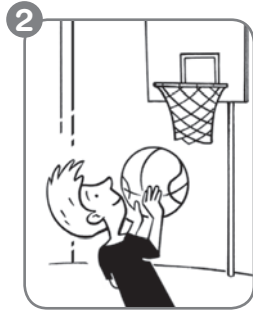

It's football.

It's a board game.

It's tag.

It's basketball.

It's a computer game.

It's hopscotch.

It's cards.

It's hide and seek.

Number 1. What's the game?



It's cards.

2 Powiedz, jakie zabawy przedstawiają cienie postaci z rysunku w ćw. 1. Zakreśl właściwe wyrazy.



It's hopscotch / football. It's hide and seek / basketball. It's cards / tag.



Lesson 2 Story

1 Podpisz rysunki. Zaznacz (✓) 5 gier z historyjki. Uzupełnij zdanie nazwami gier, których nie ma w historyjce. ✎

- | | | | |
|------------|---------------|---------------|-----------------------|
| tag | hide and seek | computer game | board game |
| basketball | hopscotch | football | cards |

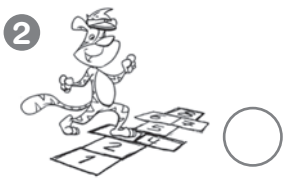

board game

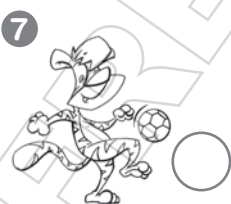
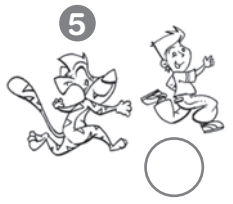

Hopscotch , _____
 and _____ aren't in the story.

2 Uzupełnij zdania i pytania. Zakreśl grę, w którą razem gra czworo przyjaciół w historyjce. ✎

I want to play
 a computer
 game.

Do you want
 to play
 _____ ?

I want to play
 _____ .

Do you want
 to play
 _____ ?





Lesson 3 Story activities – Song

1 **Uzupełnij zdania zgodnie z treścią piosenki *I want to play*.
Zaśpiewaj tę piosenkę.**

It's the break,
it's time to play.
What do you want to play today?

I want to play basketball
and h _____, too.

I want to play t _____ with you.

I want to play a C _____ g _____
and a b _____ g _____.

I want to play C _____ with you.

Let's play cards!
Yes, let's play cards!



Lesson 4 Speaking

1 Podpisz rysunki i dorysuj brakującą ilustrację. Powiedz, co widzisz na rysunkach. Zaznacz (✓) słowa, które zawierają dźwięk /ei/. 

bike snake ~~games~~ baby frog paint

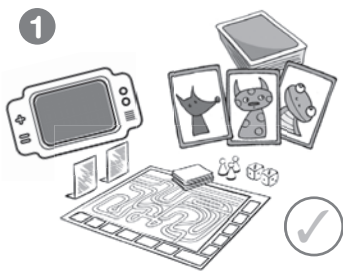

games ✓









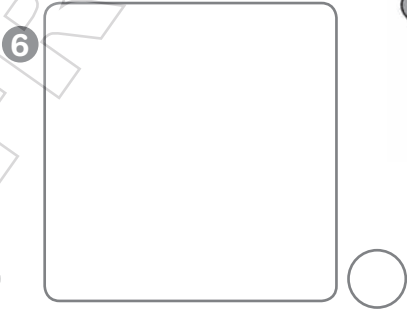

2 Uzupełnij pytania i odpowiedzi. Zakryj dymki. Odegraj scenkę z kolegą lub koleżanką. 

Do you want to play
basketball?



No, thanks.
I want to play

Do you

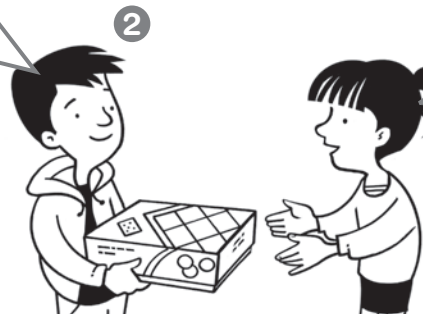

Yes. Good idea!



Lesson 5 CLIL

1 Zaznacz właściwe wyrazy. Gdzie znajduje się Pong na rysunkach?



Pong is in the **canteen** / classroom.



Pong is in the **playground** / classroom.



Pong is in the **classroom** / corridor.



Pong is in the **library** / corridor.

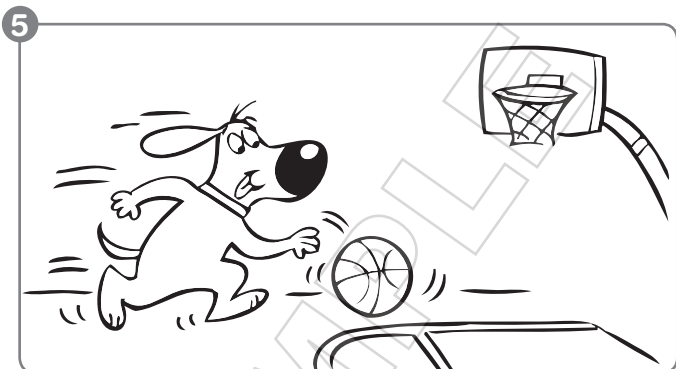

Pong is in the **gym** / library.

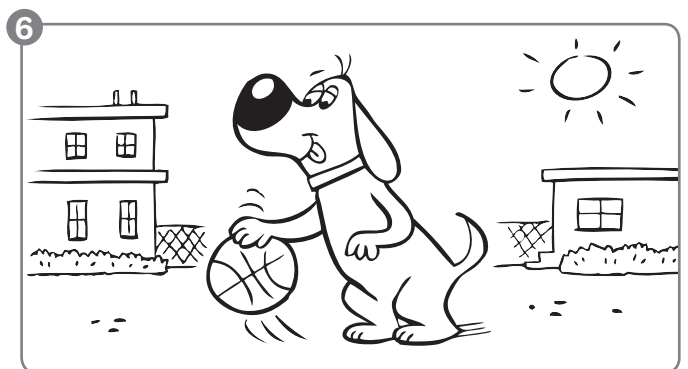

Pong is in the **canteen** / playground.

2 Połącz zdania z rysunkami.



a You can't play computer games in the classroom.

b You can't play ball games in the classroom.



Lesson 6 CLIL – Song



1 Znajdź i zakreśl 6 nazw miejsc w szkole. ✎

canteen playground gym corridor classroom library

2 Podpisz rysunki i połącz je z właściwą zasadą zgodnie z treścią piosenki *In the classroom*. Zaśpiewaj tę piosenkę. ✎



classroom

You can't play ball games in the ...

You can play ball games in the ...

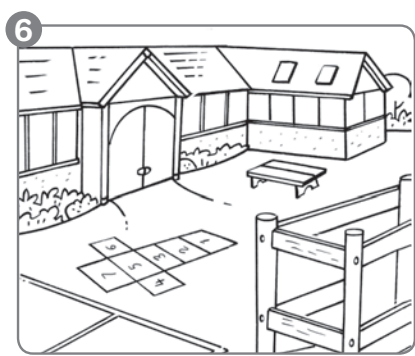
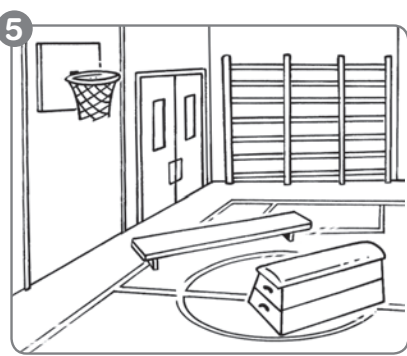

Lesson 7 Unit review

1 Dokończ rysunki i uzupełnij dialog. Zakryj dymki. Co mówią dzieci?

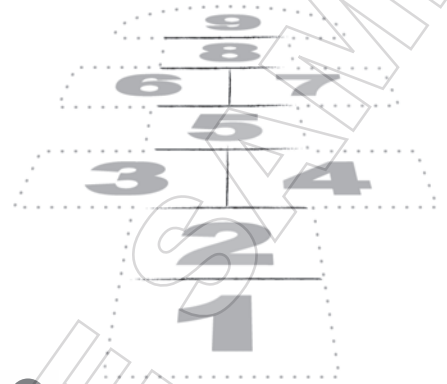
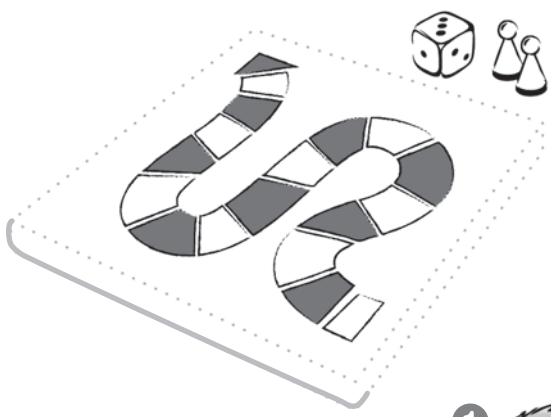

1  Do you want to play a _____ ?

2  No, thanks. I want to play _____ .

2 Uzupełnij zdania i zakreśl właściwe wyrazy. Zakryj zdania. Jakie zasady przedstawiają rysunki?



1 You can / can't play cards
in the classroom .



2 You can / can't play a _____
_____ in the _____ .



3 You can / can't play _____
_____ in the _____ .



4 You can / can't play _____
_____ in the _____ .



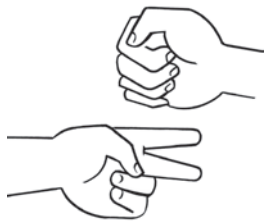

Kids' Culture 4

1 Uzupełnij zdania. Zagraj z kolegą lub koleżanką w grę *Rock, paper, scissors*.  



 =  = paper

 =  = rock

 =  = scissors

The winner is

rock

The winner is

The winner is

2 Połącz rysunki z wypowiedziami. 

W co bawisz się w szkole na przerwie? 



a We go to school in the UK. At break time, we play football.

b I play hide and seek with a friend.

c I play tag with my friends.

d I play cards in the classroom.



EARLY FINISH

1 Narysuj zabawy, o których mówią dzieci i napisz zdania pasujące do rysunków 3 i 4. 



2 Narysuj, w co chcesz pobawić się podczas przerwy. Uzupełnij zdanie zgodnie z rysunkiem. 



It's break time.

I want to play

3 Rozwiąż krzyżówkę. Wpisz nazwy miejsc, których fragmenty są widoczne na rysunkach. 

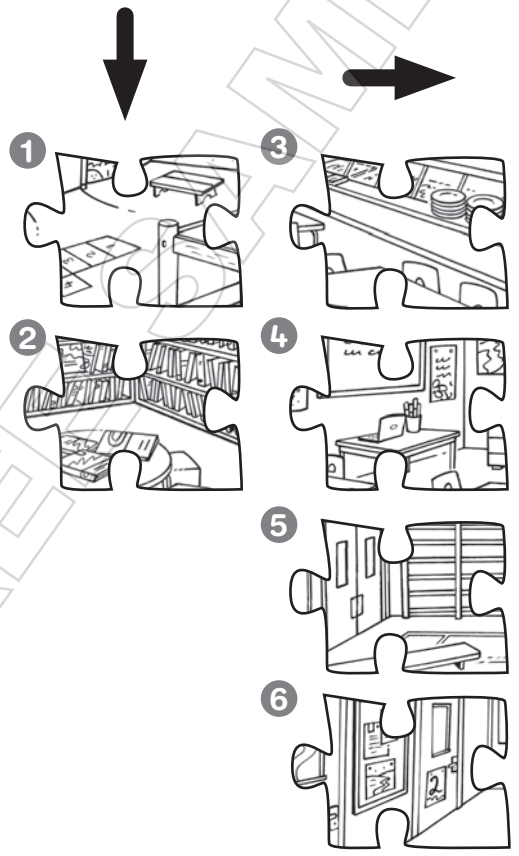
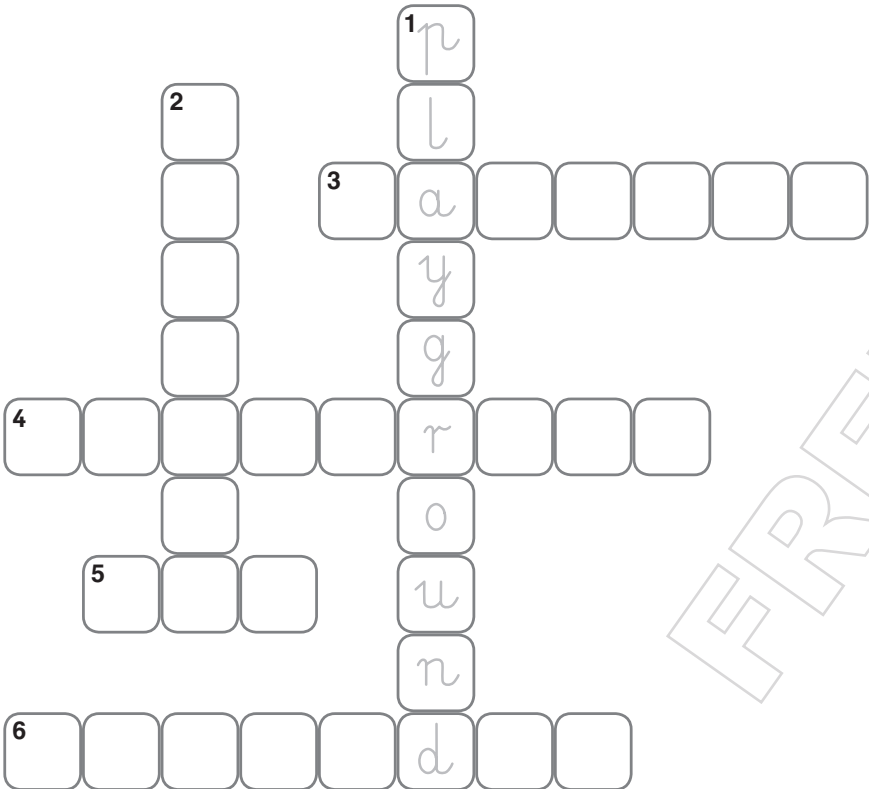

4 Narysuj zabawę, w którą można bawić się w klasie, i taką, w którą nie można. Uzupełnij zdania zgodnie z rysunkami.  

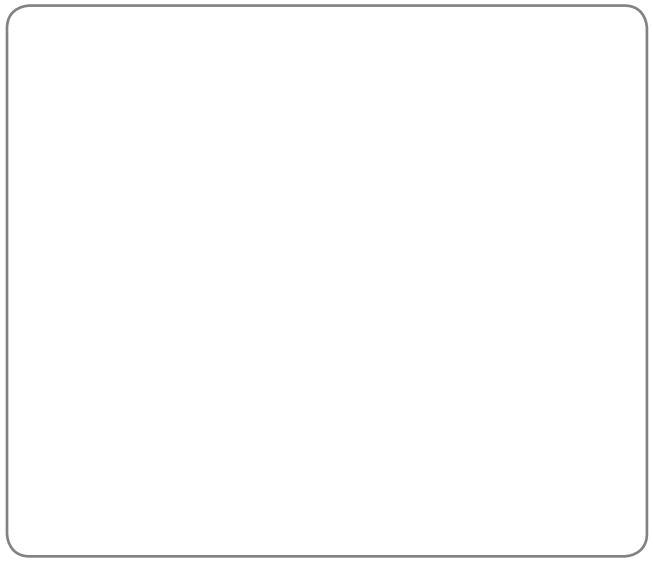
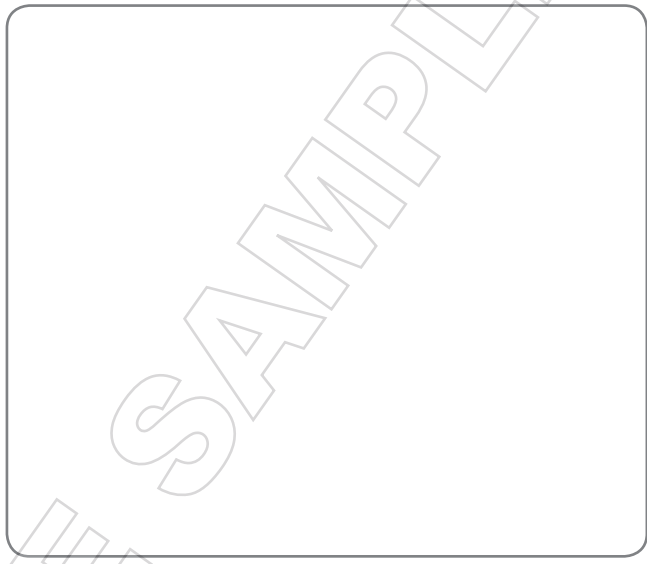

You can play _____

 in the classroom.

You can't play _____

 in the classroom.

Tiger Review 2



1 Wpisz wyrazy do właściwych ramek. Zamknij zeszyt ćwiczeń i powiedz, jakie ubrania i zabawy są na rysunkach. ✍️

Clothes

coat,



football



computer game



hopscotch



skirt



shirt



trousers



coat

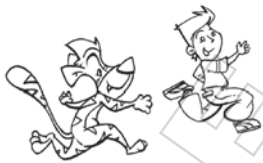

tag



cards



shoes



basketball



jumper



hide and seek



T-shirt



board game



shorts

Games

football,

2 Uzupełnij zdania. Zakryj dymki i powiedz, co mówią postaci na rysunkach.  

shorts winter basketball classroom board game coat

My favourite season is winter.



Tiger, you're wearing my _____!



I want to play _____.



Pong, stop! You can't play ball games in the _____.



Do you want to play a _____, _____, _____, Tiger?



I'm wearing _____ a _____, a jumper and shorts.



5 What's the matter?



Lesson 1 Vocabulary

1 Dopasuj osoby do zdań. Odegraj scenkę z kolegą lub koleżanką.



Number 1.
What's he got?



- 1 He's got a cough.
- 2 He's got a headache.
- 3 He's got a cut.
- 4 He's got tummy ache.
- 5 She's got toothache.
- 6 She's got earache.
- 7 She's got a cold.
- 8 She's got a sore throat.

2 Policz tygrysy na rysunku w ćw. 1 i wpisz wynik. Zakreśl właściwe wyrazy zgodnie z rysunkiem.



- 1 The big tiger has got a **headache** / **cold**.
- 2 The small tiger has got a **cut** / **sore throat**.



Lesson 2 Story

1 Podpisz rysunki. Zaznacz (✓) dolegliwości, które pojawiają się w historyjce.

- sore throat
- tummy ache
- cold
- ~~cough~~
- toothache
- cut
- headache
- earache

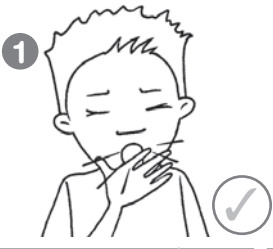

cough _____

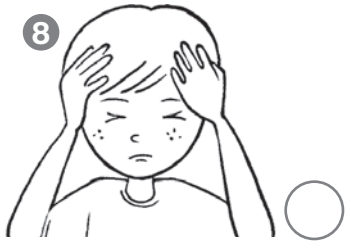
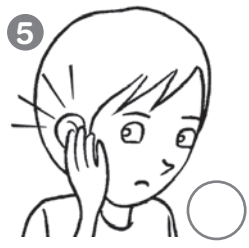

2 Uzupełnij zdania. Zakryj dymki.

Odegraj scenki z kolegą lub koleżanką.

- I've got a
headache.
- I've got a _____.
- I've _____.
- I've _____.



What's the matter?



Lesson 3 Story activities – Song



- 1 Uporządkuj litery i uzupełnij zdania.
 Zaśpiewaj piosenkę *I'm feeling ill*.

What's the matter?

How are you today?

I'm feeling ill,

so I can't play.

I can't go to school for two or three days.



I've got a sore throat **soer trohta** ,
 and a bad _____ **coguh** ,
 a sore _____ **trhota** ,
 and a bad, bad _____ **gucoh** .



I've got a _____ **hehacdae** ,
 and a bad _____ **clod** ,
 a _____ **hdaceahe** ,
 and a bad, bad _____ **dolc** .



Lesson 4 Speaking

1 Powiedz, co widzisz na rysunkach i wpisz brakujące litery.
Wybierz i przepisz słowa, które zawierają dźwięk /ɒ/.



h o t

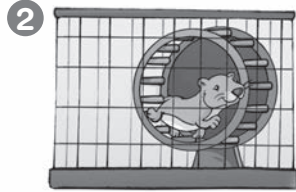

hamst er



c ough

Tiger Phonics

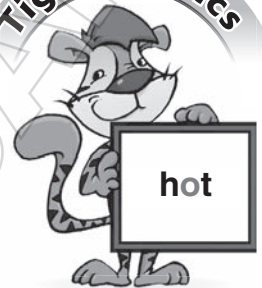

c at



h opscotch



sk ort



2 Uzupełnij dialogi. Zakryj dymki. Co mówią postaci?



What's the matter?

I'm feeling ill.

Have you got toothache?

Yes, I have.



What's the _____?

I'm feeling _____.

_____ you _____ earache?

No, I haven't.

Lesson 5 CLIL

1 Połącz rysunki z wyrazami. Co widzisz na obrazkach? 

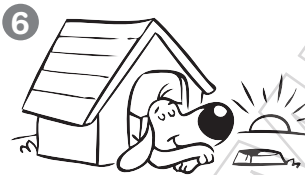

eat well

drink water

do exercise

play

sleep well

wash



2 Wybierz 3 czynności z ćw.1, które wykonujesz codziennie, i uzupełnij zdania. 

1 I _____ every day.

2 I _____ every day.

3 I _____ every day.

Lesson 6 CLIL – Song



1 **Uzupełnij zdania zgodnie z treścią piosenki *Keep healthy*.
Zaśpiewaj tę piosenkę.**

do exercise ~~drink water~~ wash eat well play sleep well

Come on everyone
Keep healthy, keep healthy.

You need to drink water



you need to _____, too.



You need to play and _____,
it's good for you.



You need to _____ your body,



you need to _____, too.



You need to _____ and do exercise.
it's good for you.

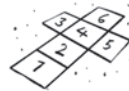

2 **Uzupełnij pytania i zakreśl właściwe odpowiedzi.**
Odegraj scenkę z kolegą lub koleżanką.

Do you do exercise
every day?



Do you _____
every day?



Yes, I do. / No, I don't.

Yes, I do. / No, I don't.



Lesson 7 Unit review

1 Uzupełnij zdania. Zakryj dymki. Co mówią dzieci?  

1  I do exercise and I _____ water.

 I'm feeling ill. I've got a sore throat.

2  I _____ well.

I'm feeling ill. I've got _____.

3  I _____ well.

I'm feeling ill. I've got a _____.

4  I _____ my hands.

I'm feeling ill. I've got _____.



Kids' Culture 5

1 Narysuj odpowiednie części ciała.

Odegraj dowcip z kolegą lub koleżanką.



Doctor, doctor!

When I touch my foot , it hurts.

When I touch my leg , it hurts.

When I touch my arm , it hurts.

When I touch my nose , it hurts.

Doctor, what's the matter with me?

Hmm. You've got a broken finger. 



2 Uzupełnij zdania. Jak ty dbasz o swoje zdrowie?

I h i d e h i d e hide
and seek with my
friends in the park.

I d e r u n o n every day. I run with my
dog in the park.

I d r e w e l l every day and I eat well.

1



2



3



EARLY FINISH

1 Ułóż zdania z rozsypanki wyrazowej. Podpisz postaci właściwymi imionami. 

a



b



c



d



Oliver

1 Oliver a got cut has

Oliver has got a cut.

2 cough Jo got has a

3 has Sam tummy ache got

4 has Emily toothache got

2 Znajdź i napisz, co dolega dzieciom. 

1



2



3



4



a



b



c



d



1 She's got a cold.

3

2 He's got _____.

4

3 Popatrz na to, co robią dzieci w trosce o swoje zdrowie.
Uzupełnij zdania. 



I play every day.



I _____ every day.



4 Uzupełnij pytania. Odpowiedz na nie, wpisując *Yes, I do* lub *No, I don't*. 

1 Do you wash  every day? _____

2 Do you _____  every day? _____

3 Do you _____  every day? _____

4 Do you _____  every day? _____

5 Do you _____  every day? _____

6 Do you _____  every day? _____



6 On Holiday



Lesson 1 Vocabulary

1 Dopasuj miejsca do zdań. Odegraj scenkę z kolegą lub koleżanką.

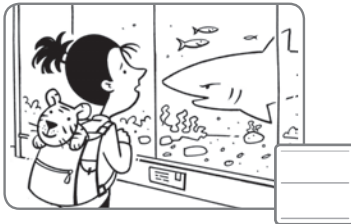
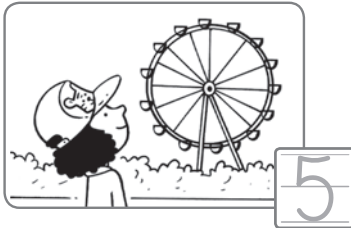

- 1 It's an ice rink.
- 2 It's a park.
- 3 It's a swimming pool.
- 4 It's a zoo.
- 5 It's a funfair.
- 6 It's a water park.
- 7 It's a beach.
- 8 It's an aquarium.

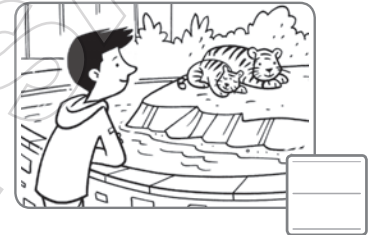

Number 1. What is it?



It's an ice rink.

2 Popatrz na fragmenty rysunków z ćw. 1. Zaznacz (✓) zdania prawdziwe lub (X) zdania fałszywe.



It's a park. (X)

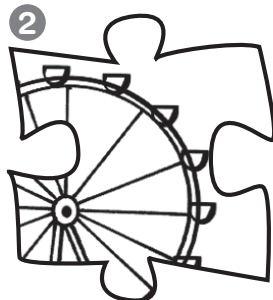

It's a funfair. ()



It's a zoo. ()



It's an aquarium. ()



Lesson 2 Story

1 Podpisz rysunki. Uzupełnij wypowiedź Tygrysa nazwą miejsca, które najpierw chce odwiedzić w historyjce.

funfair water park beach ice rink ~~park~~ swimming pool zoo aquarium



park

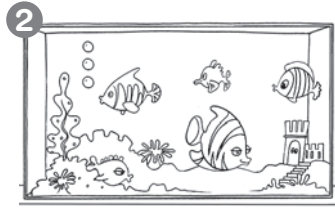











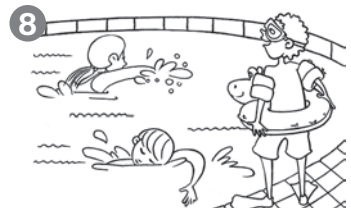

I want to go to the _____.



2 Uzupełnij zdania. Zakreśl miejsce, do którego idą wszyscy bohaterowie historyjki.



1 There's a *funfair*.

2 There's an _____.

3 There's a _____.

4 There's a _____.

5 There's a _____.

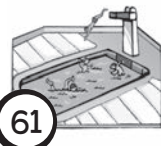



Lesson 3 Story activities – Song

1 Uzupełnij zdania zgodnie z treścią piosenki *In this town*.

Zaśpiewaj tę piosenkę.

In this town,

there's a lot to do.

There's an ice rink,

and a Z.

There's a very long t,

a s r,

and a funfair, too!

Let's go to the funfair!

In this town,

there's a lot to do.

There's a w r,

and a zoo.

There's a very big r,

an a,

and a f, too!

Let's go to the funfair!

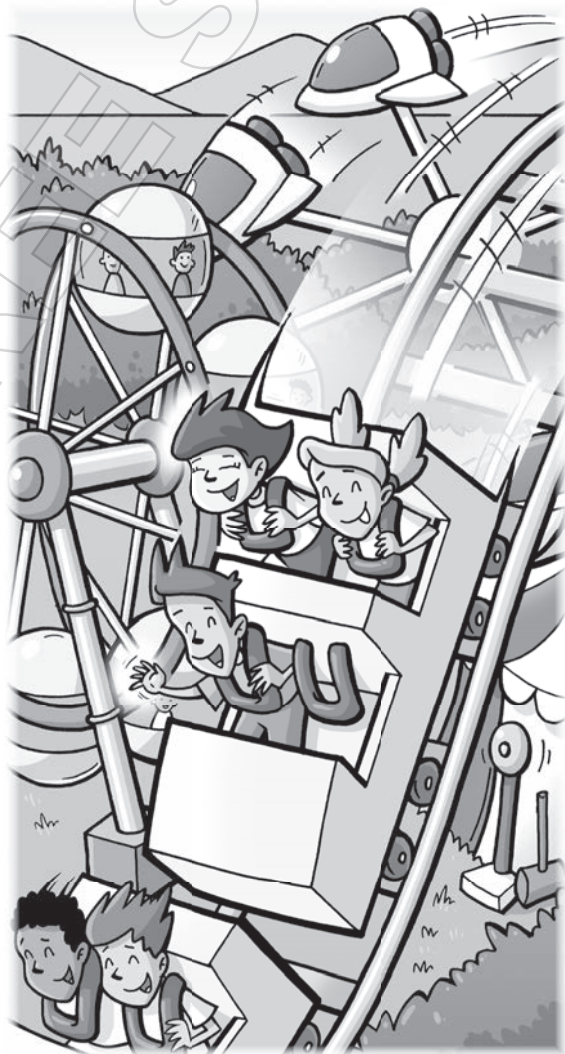

Lesson 4 Speaking

1 Powiedz, co widzisz na rysunkach i wpisz brakujące litery. Wybierz i przepisz słowa, które zawierają dźwięk /æ/.

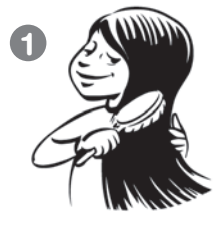

1
h a i r



2
bedr _____



3
f _____ ball



4
b _____



5
tr _____

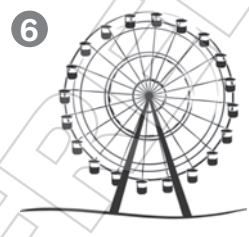

6
funf _____

hair

2 Uzupełnij pytania. Narysuj ☺ lub ☹ na twarzach postaci zgodnie z ich odpowiedziami. Odegraj scenki z kolegą lub koleżanką.

1
Is there a zoo ?

Yes, there is.

2
Is _____

No, there isn't.

3

Yes, there is.

1 Połącz zwroty z rysunkami. Jakie zasady widzisz na rysunkach?

look left

stop

cross the road

stand on the pavement

listen

look right



2 Podpisz rysunki właściwymi poleceniami z ćw.1. W każdej parze rysunków zaznacz (✓) prawidłowe zachowania.

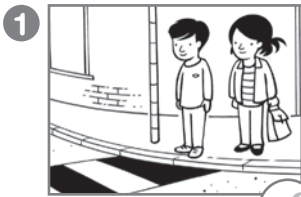

Stop.

S o t p

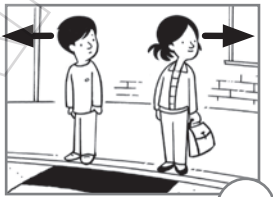
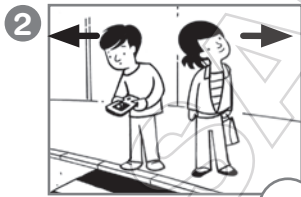

L

L t

L r



C t r

Lesson 6 CLIL – Song



1 Ponumeruj zwrotki piosenki *The road safety* w kolejności zgodnej z diagramem i jej treścią. Zaśpiewaj tę piosenkę.

Do you want to cross the road?
Yes, I want to cross the road.

No cars. No cars.
No bikes. No bikes.

Stop. Stop.

You can cross the road now.
I can cross the road now.

Stand on the pavement.
Stand on the pavement.

Look left. Look right.
Look left. Look right.



2 Jak powinny zachować się dzieci na rysunkach?
Zakreśl właściwe zasady.



Listen / **Don't listen** to music.



Play / **Don't play** ball games.



Stand / **Don't stand** in the road.

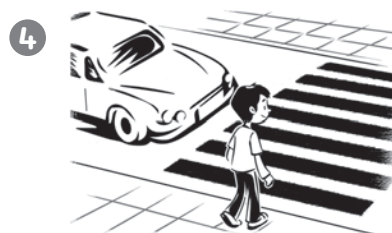

Look / **Don't look** left.



Lesson 7 Unit review

1 Co mówią postaci na rysunku? Uzupełnij ich wypowiedzi. Znajdź i zakreśl 9 różnic między rysunkami.

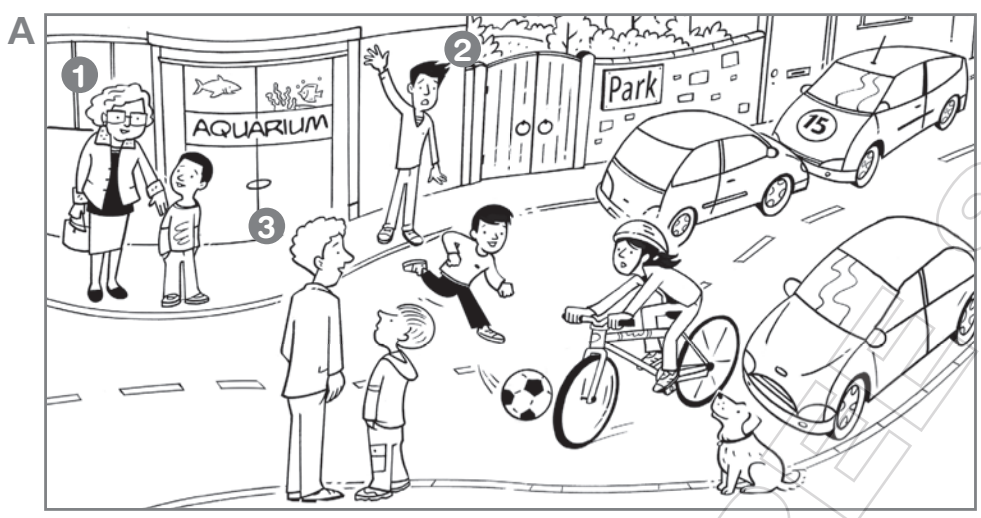

1
Stand _____
on the pavement.

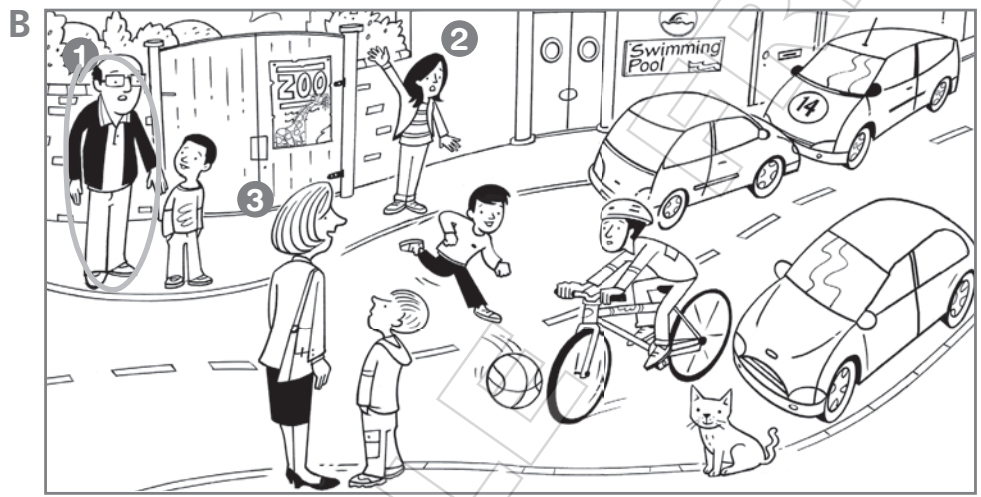

2
Don't _____
the road.

3

_____ left and right.

2 Napisz i powiedz, jakie miejsca znajdują się tylko na rysunku A, a jakie tylko na rysunku B w ćw. 1.

Picture A

- 1 There's an aquarium.
- 2 There's a _____.

Picture B

- 3 _____
- 4 _____





Kids' Culture 6

1  Ponumeruj fragmenty rymowanki *A sailor goes to sea* w kolejności zgodnej z jej treścią. Powiedz tę rymowankę.  

- to see what he can see, see, see.
- But all that he can see, see, see,
- 1 A sailor goes to sea, sea, sea,
- is the bottom of the deep blue sea, sea, sea.



2 Uzupełnij wypowiedzi. Jakie ciekawe miejsca znajdują się w twoim mieście?  



In my town, there's

a cinema.

I go there every week.



In my town,

I go swimming every week.





In

I play there with my friends every week.

EARLY FINISH

1 Narysuj w każdym rzędzie dwa brakujące symbole miejsc. 

1						
2						
3						

2 Uzupełnij zdania. Narysuj miasto zgodnie ze zdaniami.  

1 There's a zoo .



4 There's an _____ .



2 There's a _____ .



5 There's a _____ .



3 There's a _____ .



6 There's a _____ .



3 Narysuj ilustracje zgodne z poleceniami 1, 3, 5 i napisz polecenia pasujące do rysunków 2, 4, 6. 

Road safety

1



Stop

2



Listen

4





5



Look right

6



4 Ułóż z rozsypanki wyrazowej zakazy związane z bezpieczeństwem na drodze. Dodaj jeszcze jeden zakaz. 

1 play Don't tag

Don't play tag.

2 the road Don't in stand

3 listen to Don't music



4 games play Don't ball

5



Tiger Review 3



1 Wpisz wyrazy do właściwych ramek. Zamknij zeszyt ćwiczeń i powiedz, jakie dolegliwości i miejsca są na rysunkach.  

Health problems

cough,



cough



earache



ice rink



zoo



headache



water park



funfair



sore throat



park



cut



beach



swimming pool



toothache



tummy ache



cold

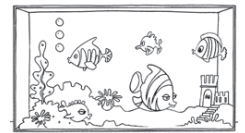

aquarium

Places

funfair,

2 Uzupełnij zdania. Zakryj dymki i powiedz, co mówią postaci na rysunkach.  

ice rink pavement ~~drink~~ There's tummy ache feeling

I drink
water every day,
Ping. Look! I eat
well, too.



Stand on the _____.
Remember to look left and right.



I'm _____
better now.



There's an _____
_____.



Look, Tiger.
_____ a lion.



I've got _____
_____.

