

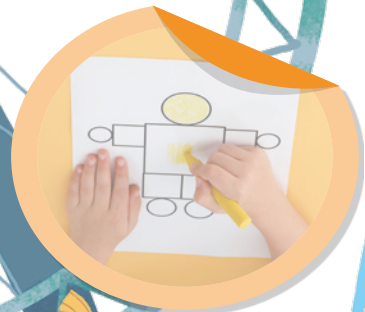

School

A new friend



Listen, point and repeat. Listen and stick the school activity stickers. Listen and play *Memory*. Circle the activities you like. Say. **Language:** colour, count, draw, paint, play, sing; blue, green, orange, pink, red, yellow; Where's (draw)? It's on (red).

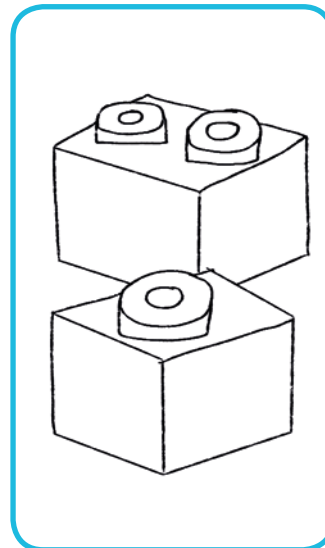
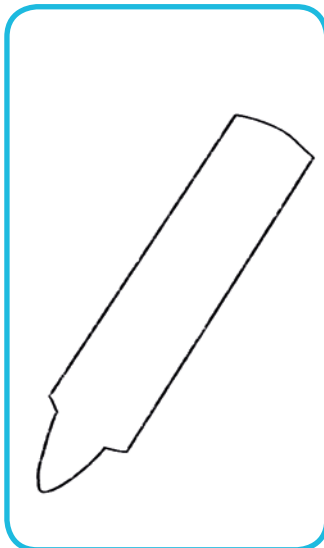
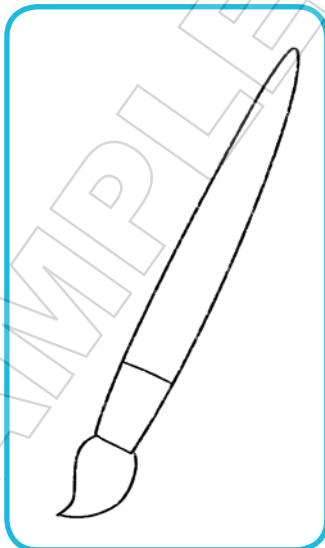
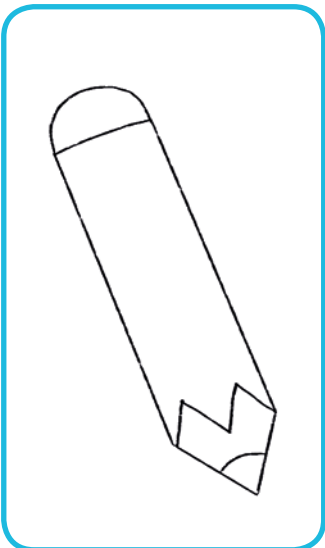
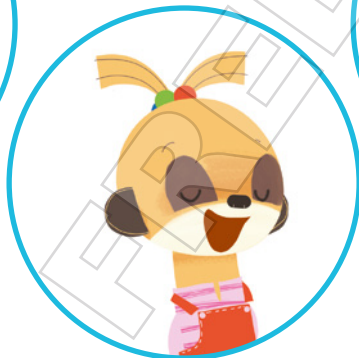

Look and match. Colour, point and say.
Language: colour, count, draw, paint, play, sing





Listen and find the new school activities. Listen, point and sing *What do you do at school?* Match the activities to Lucy and Alex. Ask and say. **Language:** count, dance, draw, jump, paint, run, sing, think; What do you do at school? I (draw) at school.

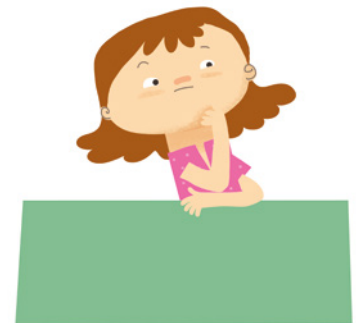

Circle the activities you do at school. Ask and say.

Language: colour, count, dance, draw, jump, paint, play, run, sing, think;
What do you do at school? I (sing) at school.



Watch. Listen to the story **A new friend**. Circle who's new at school. Stick the story sticker.
Language: colour, count, dance, draw, jump, paint, run, sing, think; What do you do at school?
 I (think) at school. Do you want to (colour)? Yes, I do. / No, I don't. I want to (jump).



Watch. Listen, point and sing *Katy Kangaroo*. Trace ✓ or X to show what Katy does and doesn't want to do. Trace and colour Katy. Ask and say. **Language:** colour, count, draw, jump, paint; Do you want to (draw)? Yes, I do. / No, I don't. I want to (jump).



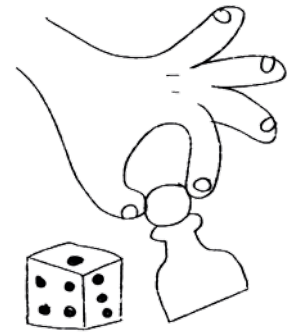
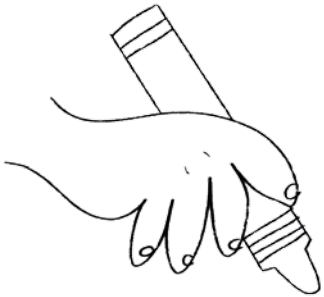

Watch. Listen and point. Circle what Alex and Lucy want to do. Colour what you want to do. Ask and say. **Language:** colour, dance, draw, paint, play, sing; Do you want to (paint)? Yes, I do. / No, I don't. I want to (play outside).







Listen and point. Match the activities to Auntie Vicky, Alex and Lucy. Circle the pictures to show exercise you do. Ask and say. Language: dance, play football, ride my bike, run, swim, walk (to school); What exercise do you do? I (play football).





1 2 3 4



Watch. Listen, point and sing *Go in and out the window*. Match and number the photos in order.

Language: dance, go, shake hands, stand; partner, window; numbers 1-4





Review

School



I can ...

Vocabulary



Story



Speaking



Content



Circle the school activities you know. Listen, point and say. Listen and answer. Ask and say. Complete the faces to show what you can do. **Language:** colour, count, dance, draw, jump, paint, play, run, sing, think; What do you do at school? I (draw) at school. Do you want to (sing)? Yes, I do. / No, I don't. I want to (paint).

Project



School

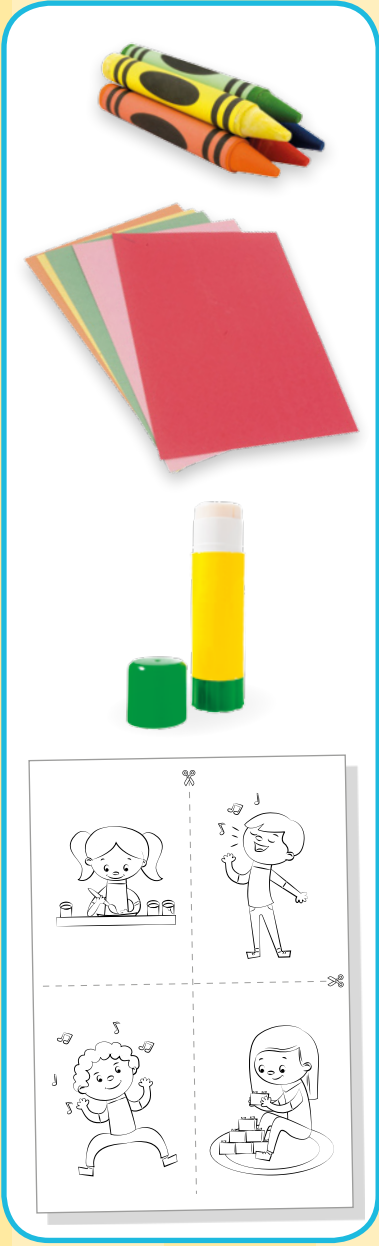

Choose and colour your favourite school activity. Stick your picture on the chart. Ask and say. Language: dance, paint, play, sing; colours; numbers; chart, fantastic, great, picture; What do you do at school? I (dance) at school. How many people (dance)? (Four). Do you want to (paint)? Yes, I do. / No, I don't. I want to (play). Our chart is (fantastic).