



1 Welcome to School



Lesson 1 Vocabulary

1 Dokończ rysunki przyborów szkolnych i połącz je z właściwymi półkami. Jakie przybory widzisz na rysunku? 

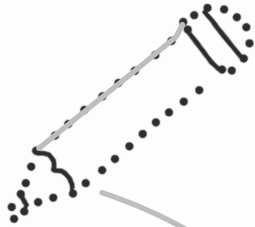

pencil

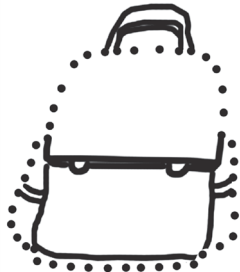

bag

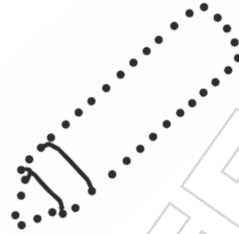

crayon



pen

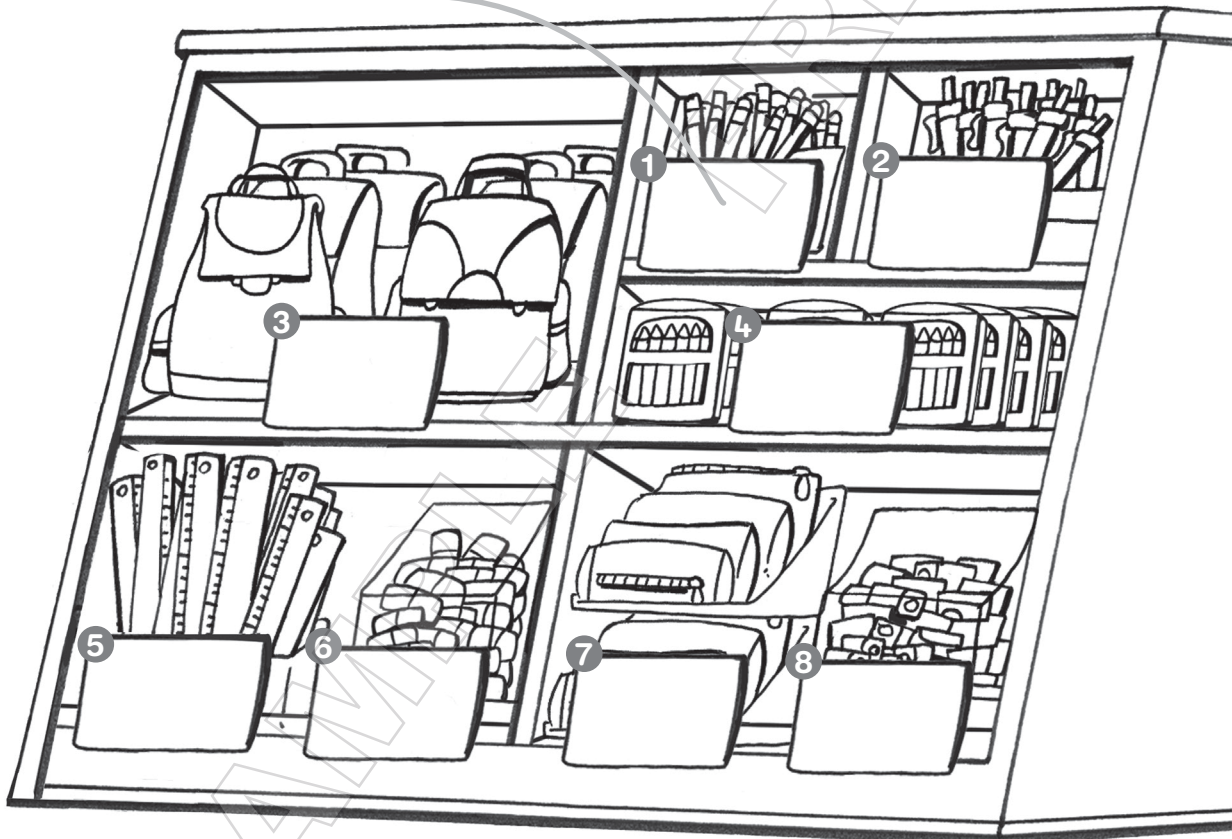

rubber



sharpener

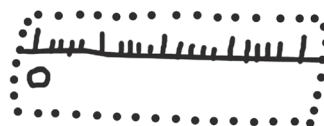

ruler

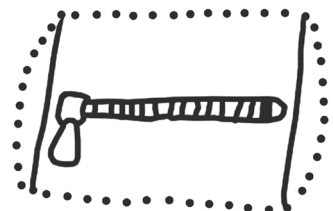

pencil case



Lesson 2 Story



VIDEO 01 STORY TIME

1 Zaznacz (✓) i powiedz, które przybory kupiły dzieci. 

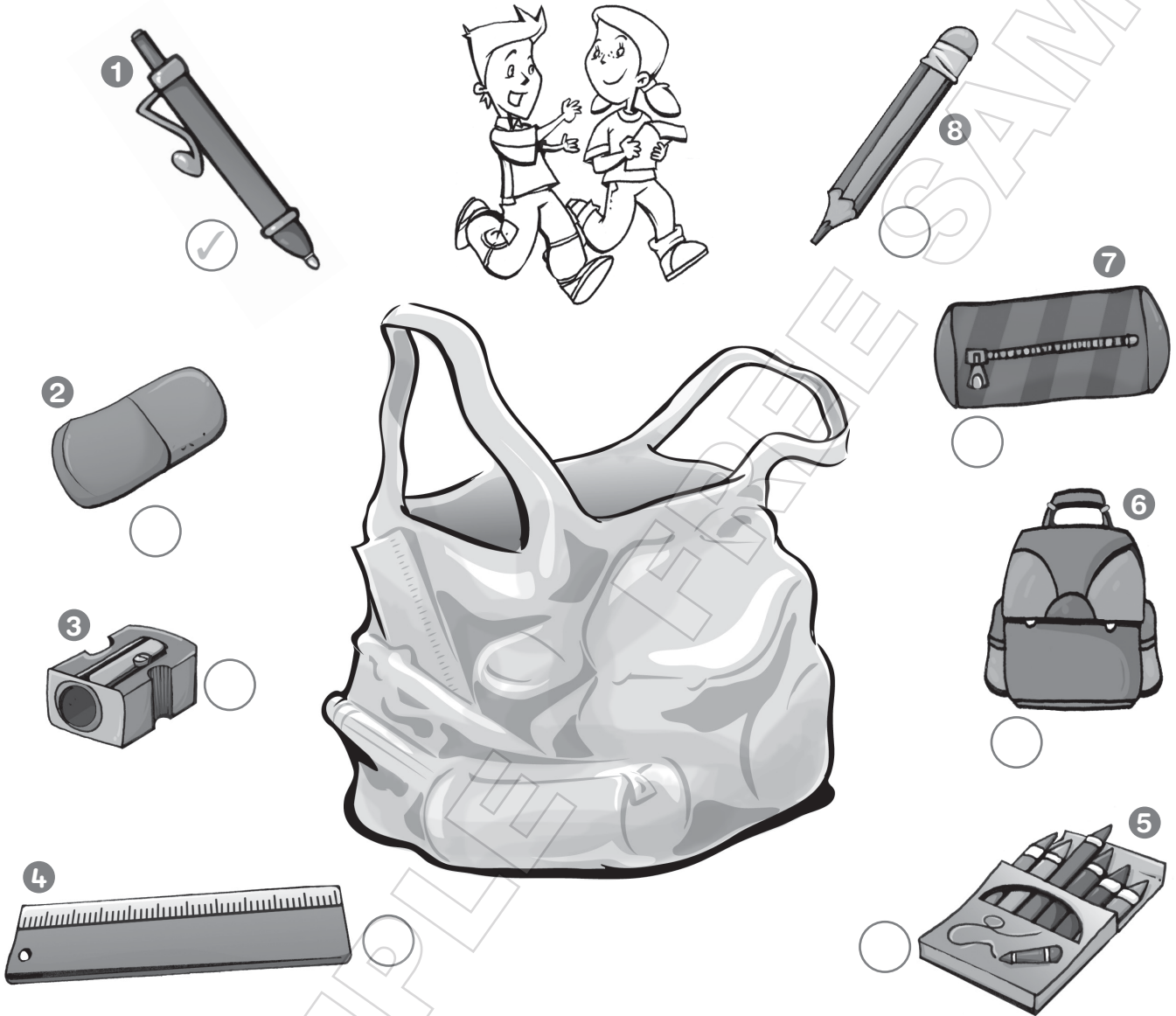

2 Przeczytaj podpisy i zakreśl właściwe rysunki. 

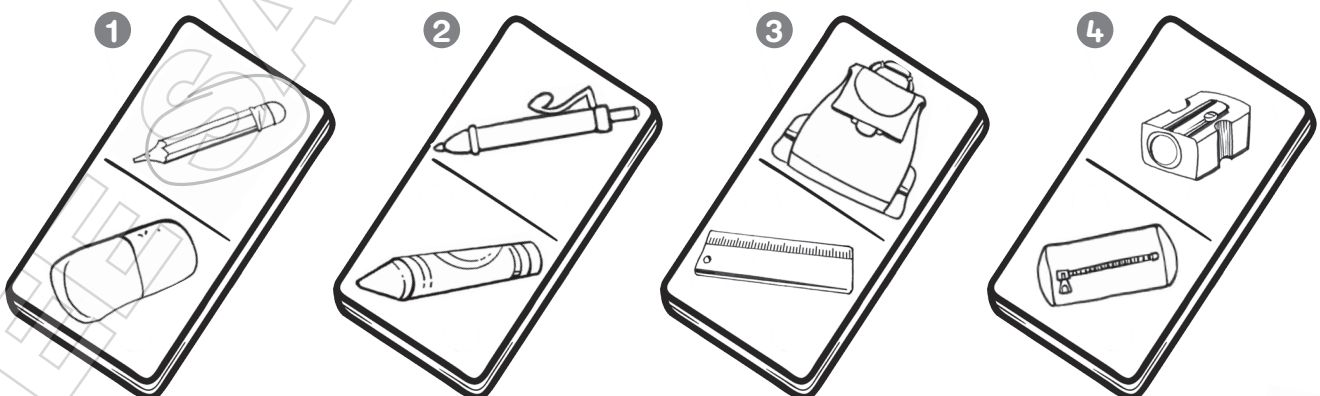

pencil

crayon

ruler

sharpener





Lesson 3 Story activities - Song

1 1.24 Narysuj drogę przez labirynt i zbierz przedmioty z piosenki *Can I have this pen, please?*. Zaśpiewaj tę piosenkę.

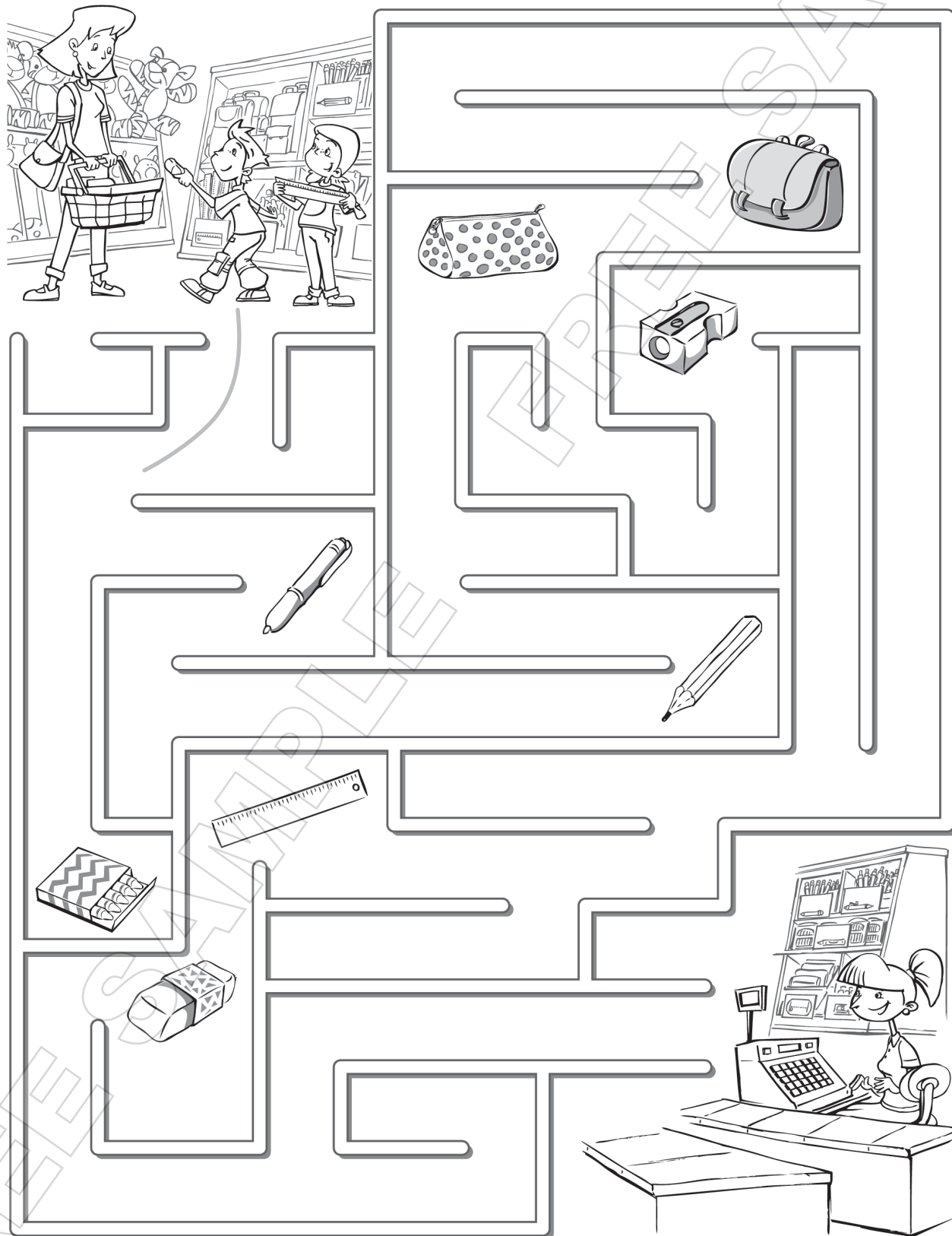

Lesson 4 Speaking

1 Powiedz, co widzisz na rysunkach. W każdym rzędzie zakreśl słowo, które zawiera dźwięk /æ/ (jak w wyrazie *black*).

1

2

3

2 Połącz kropki. O co proszą dzieci i jakie słyszają odpowiedzi?

Lesson 5 CLIL

1 Połącz rysunki. Jakie czynności wykonują postaci? 



draw

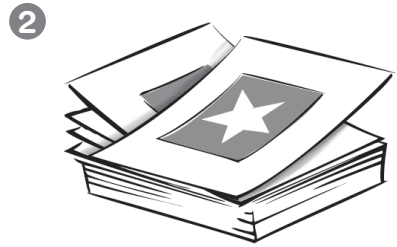

play



sing

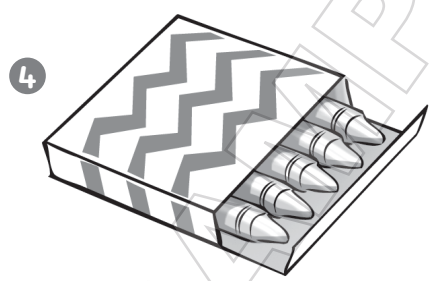

colour



talk





Lesson 6 CLIL – Song

1 1.33 Ponumeruj rysunki zgodnie z treścią piosenki
I draw at school. Zaśpiewaj tę piosenkę.

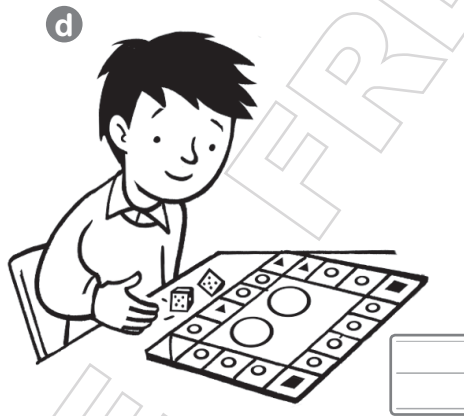

2 Połącz wyrazy z ilustracjami. Dorysuj w ramce brakujący przedmiot.

1 sing

2 colour

3 draw

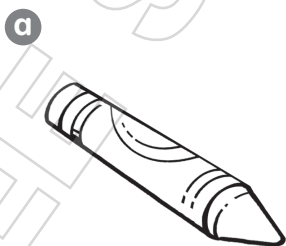



Lesson 7 Unit review

1 Połącz połówki przedmiotów. Jakie przybory szkolne widzisz na rysunkach?

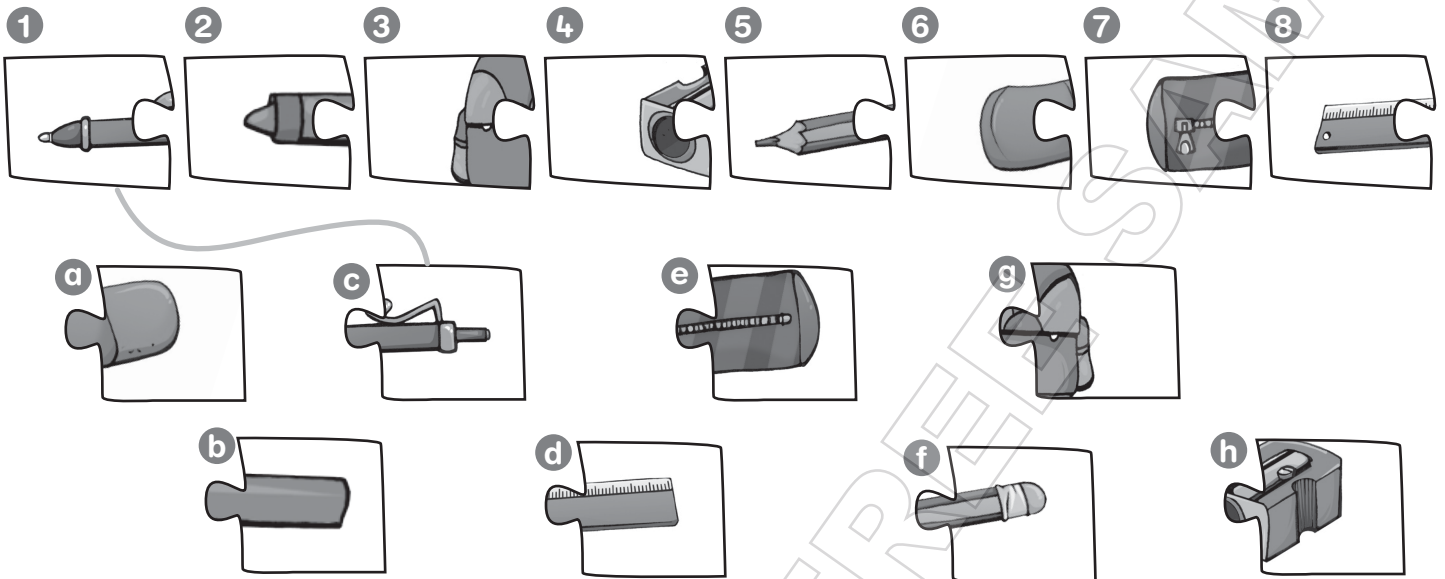

2 Połącz trójkąty z fragmentami rysunku. Co robią dzieci?



3 Jak oceniasz swoją pracę w rozdziale 1.? Pokoloruj wybraną postać.

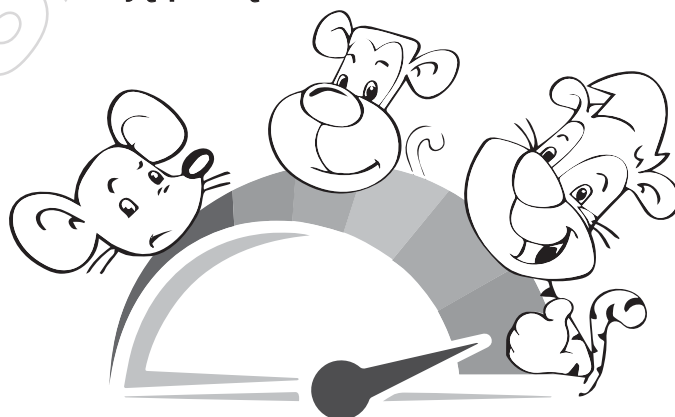

Ocenianie kształtujące



Kids' Culture 1



▶ VIDEO 02

- 1 1.38 Narysuj siebie i napisz brakujące cyfry zgodnie z treścią rymowanki *Two, four, six, eight*.



2 4 8

2 6

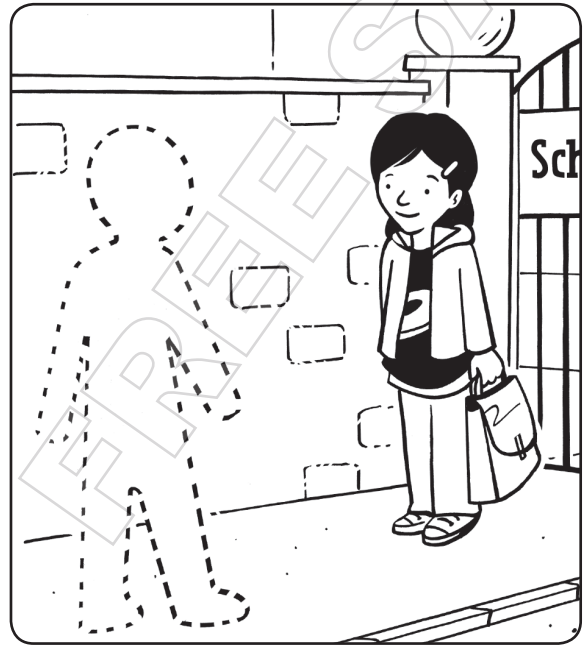

- 2 Co robią dzieci w polskiej szkole? Zaznacz (✓) te czynności, które widzisz na zdjęciu.



Poland

draw

colour

sing

talk

play





EARLY FINISH

1 Dokończ rysunki i je pokoloruj. 

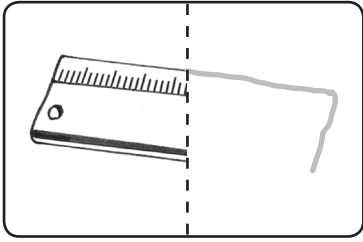

ruler

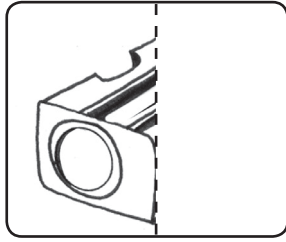

sharpener

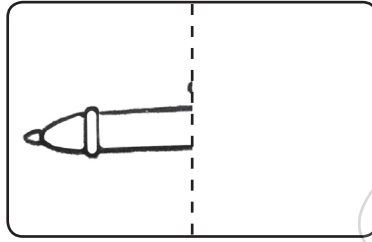

pen

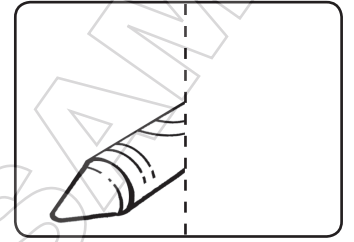

crayon

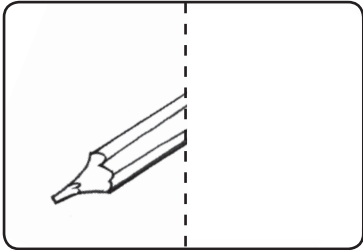

pencil

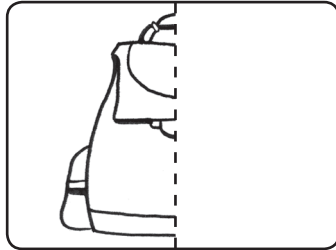

bag

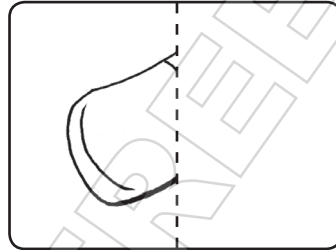

rubber

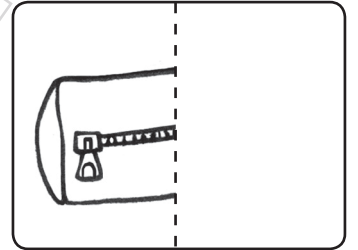

pencil case

2 Narysuj, co jest w twoim piórniku, i pokoloruj rysunek.

*Możesz napisać wyrazy po śladzie.  

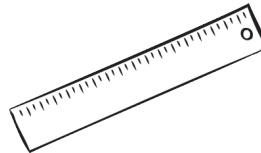
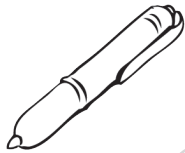
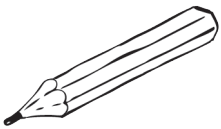

pencil

pen

crayon

ruler

sharpener

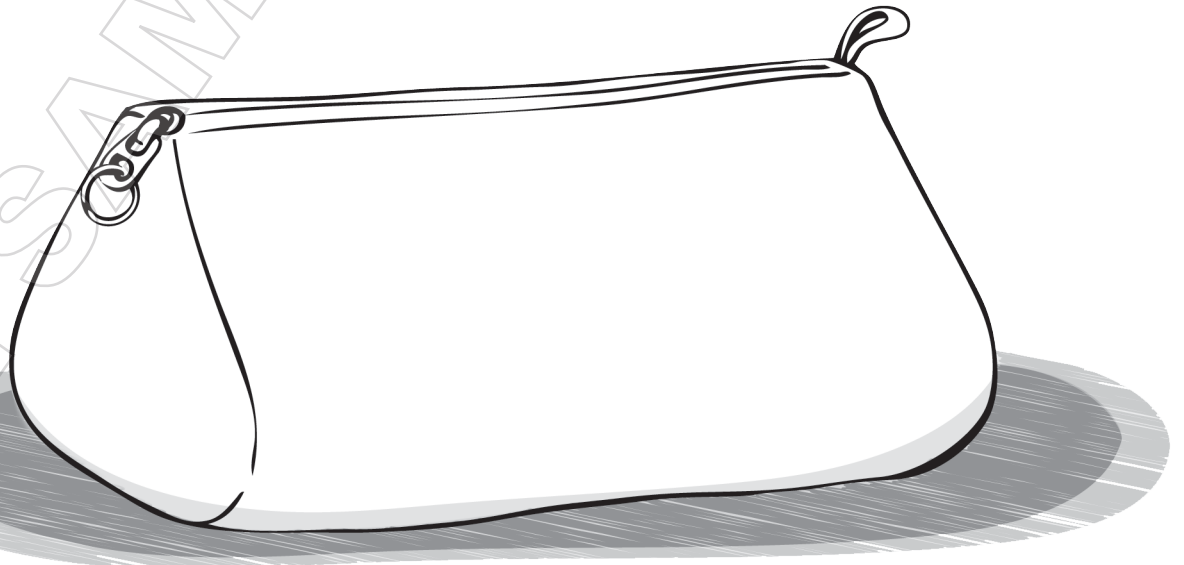

3 Dokończ rysunki i je pokoloruj.



draw



sing



talk



play



colour

4 Połącz rysunki ze zdaniami. *Możesz napisać wyrazy po śladzie.



a I sing at school.



b I play at school.



c I draw at school.