

1 ★ Uzupełnij zdania, wpisując słownie wiek bohaterów.

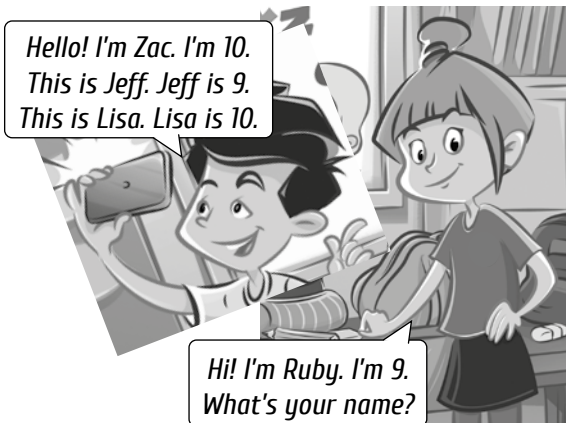

- Zac is ten.
- 1 Jeff is _____.
 - 2 Lisa is _____.
 - 3 Ruby is _____.
 - 4 My name is _____. I'm _____.

2 ★ Popatrz na kartki urodzinowe i napisz, ile lat ma każdy jubilat.



Sally is twelve.

1 _____



2 _____



3 _____



4 _____



5 _____



Phonics

03 Posłuchaj nagrania i dopasuj kolejne litery alfabetu do odpowiednich kategorii. Które dwie litery nigdzie nie pasują?

two three seven eight nine

Q B F A I

Niepasujące litery to: _____ oraz _____.

3 ★★ 04 Posłuchaj nagrania i uzupełnij informacje.

1 Name: _____ Age: _____

2 Name: _____ Age: _____

3 Name: _____ Age: _____

4 Name: _____ Age: _____

5 Name: _____ Age: _____

6 Name: _____ Age: _____

4 ★★★ Przedstaw trzech kolegów / trzy koleżanki i podaj ich wiek.

This is Marek. Marek is ten.



1 Uzupełnij zdania odpowiednią formą czasownika **be**.

- 1 You _____ very nice.
- 2 He _____ my new friend.
- 3 We _____ in trouble.
- 4 Hi, I _____ Emma.
- 5 They _____ angry.

2 Popatrz na ilustracje i uzupełnij zdania wyrażeniami z ramki.

She is ■ They are ■ He is
I am ■ We are ■ You are



You are Kevin.



_____ Ted.



_____ Becky.



_____ Katie
and Amy.



_____ Ben
and Sam.



_____ Eric.

3 ★ Zakreśl poprawne odpowiedzi.

- 1 We **is / are** nine.
- 2 I **am / are** Harry.
- 3 You **am / are** my friend.
- 4 Nina and Maya **is / are** cats.
- 5 Nina **is / are** two.
- 6 He **is / are** fifteen.

4 ★ Przepisz zdania, używając pełnych form czasownika **be**.

- We're friends. We are friends.
- 1 She's ten. _____
 - 2 I'm eight. _____
 - 3 You're Anna. _____
 - 4 It's a dog. _____
 - 5 They're goldfish. _____

5 ★★ Uzupełnij tekst odpowiednimi formami czasownika **be**.











I 'm Ed and I ¹ _____ nine. My friends ² _____ Yasmin and Ollie. Yasmin ³ _____ ten and Ollie ⁴ _____ nine. Jello and Rocco ⁵ _____ my dogs. They ⁶ _____ also my friends!

6 ★★★ Uzupełnij tabelę informacjami o swoich przyjaciółach i zwierzętach domowych, jeśli je masz. Potem opisz ich/je.



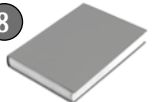





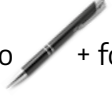

| FRIEND | | PET | |
|--------|-----|------|-----|
| Name | Age | Name | Age |
| | | | |
| | | | |
| | | | |

My friends are _____

1 ★ Uzupełnij podpisy zdjęć brakującymi literami.

- 1  r _ _ _ e _ _
- 2  _ o _ _ u _ _ r
- 3  p _ _ c _ _ c _ _ e
- 4  b _ _ r _ _
- 5  _ h _ _ r
- 6  _ e _ _ i _ _
- 7  _ _ _ s _ _
- 8  b _ _ _ _
- 9  s _ _ o _ l _ _ g
- 10  p _ _ _
- 11  _ _ t _ _ o o _ _

2 ★★ Napisz słownie wyniki działań matematycznych.

- two  + four  + six  = twelve pens
- 1 nine  x 2 = _____
- 2 one  + seven  - three  = _____
- 3 sixteen  ÷ 2 = _____
- 4 twenty  - three  = _____

3 ★★ Przeczytaj opisy i dopasuj do nich właściwe zestawy ilustracji.

- 1 Two notebooks, three pens, one desk and one book. Picture
- 2 One notebook, two pencils, two pens and two desks. Picture
- 3 One desk, one notebook, three books and three pens. Picture
- 4 One pencil, two notebooks, two pens and one desk. Picture

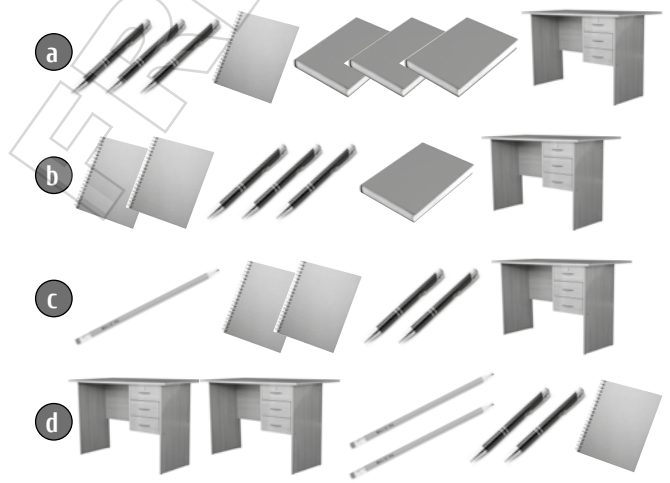

4 ★ Narysuj przedmioty zgodnie z opisem.

- 1 four rubbers
- 2 one pencil case
- 3 two chairs
- 4 three boards

| | |
|---|---|
| 1 | 2 |
| 3 | 4 |



1 Uzupełnij tekst, wpisując **a, an** lub **-**.

My school things

School | June 23, 2019 | 15 Comments

I have ¹ _____ orange schoolbag with ² _____ green monster. In my schoolbag, I have ³ _____ three pens, ⁴ _____ pencil and ⁵ _____ four notebooks. I like my bag and I like my school.

2 ★ Zakreśl poprawne przedimki.

- 1 **a / an** orange car
- 2 **a / an** bad invention
- 3 **a / an** inventor
- 4 **a / an** amazing computer
- 5 **a / an** pink desk
- 6 **a / an** big chair

3 ★★ Uzupełnij zdania, wpisując **a, an** lub **-**.

- 1 My dad is _____ inventor.
- 2 Mr Smith and Mrs Jones are _____ teachers.
- 3 Hannah is _____ student.
- 4 It is _____ orange pencil.
- 5 It is _____ good invention.
- 6 They're _____ rubbers.

4 ★★★ Oto najnowszy wynalazek Iggygo – robot, który uczy się języka angielskiego. Pomóż mu ułożyć poprawne zdania.



are chairs They big green.

They are big green chairs.

- 1 small is red It desk a. _____
- 2 beautiful is white It a notebook. _____
- 3 are pencils They very small. _____
- 4 big It an computer is amazing. _____
- 5 desks very They are big. _____

Useful!

Uzupełnij dialog zdaniami z ramki.



What a small notebook!
Be careful! ■ Nice to meet you!

Hello! My name's Faye. Hi Faye! _____



My dad's an inventor. Look at this! Wow! ² _____



³ _____





1 ★ Zapisz słownie podane liczby i odczytaj hasło krzyżówki.

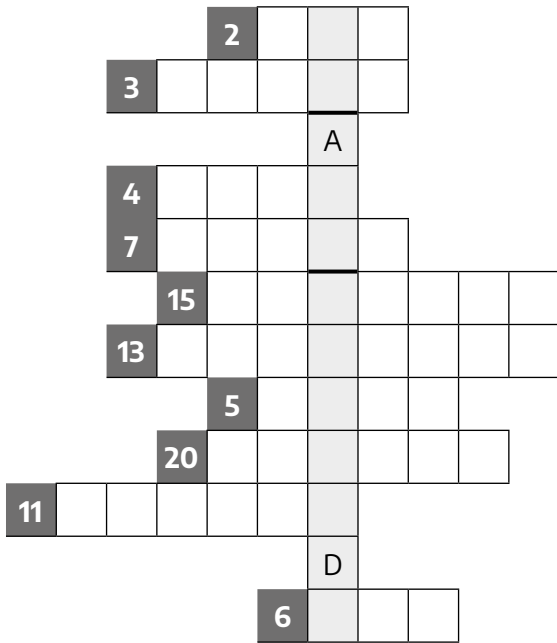

The hidden message is:

2 ★★ Wpisz słownie brakujące liczby.

1 _____, three, five, seven, _____,
eleven, _____, fifteen, _____,

2 eighteen, _____, _____, fifteen,
_____, thirteen, _____, eleven

3 two, five, _____, eleven, _____,
_____, twenty

3 ★★ Odgadnij wiek podanych osób.
Następnie zaszyfruj swój wiek.

Jane = $12 \times 2 - 9$ Jane is fifteen.

1 Tom = $17 - 13 + 4$

2 My dog = $18 \div 6$

3 Greg and Daisy = $10 \times 3 - 18$

4 My friend and I = $3 + 4 + 5 - 1$

5 I = _____

4 ★★ ★★ Znajdź w wężu wyrazowym jeszcze cztery zdania. Zapisz je, używając form skróconych czasownika *be*, a następnie zaznacz odpowiadające zdaniom ilustracje.

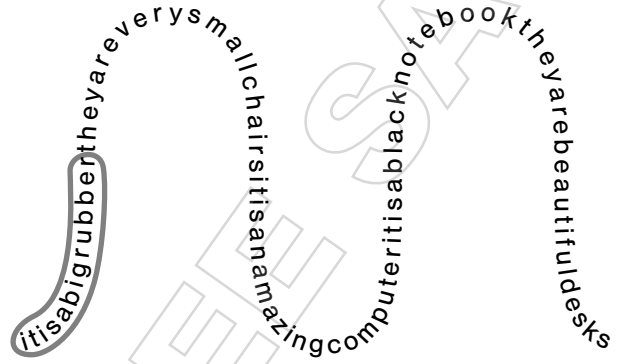

It's a big rubber.

a

b

1 _____

a

b

2 _____

a

b

3 _____

a

b

4 _____

a

b

1 ★ Połącz wyrazy z liczbami.

- | | |
|-----------------|------|
| 1 twenty-five | a 84 |
| 2 thirty-seven | b 73 |
| 3 eighty-four | c 25 |
| 4 forty-eight | d 52 |
| 5 fifty-two | e 37 |
| 6 seventy-three | f 48 |

2 ★ Zapisz liczby słownie.

- 1 91 _____
- 2 100 _____
- 3 26 _____
- 4 63 _____
- 5 55 _____
- 6 39 _____

3 ★★ Uzupełnij dialog wyrazami z ramki.

spell ■ twelve ■ name ■ old ■ What

A: What's your name ?

B: My name's Isobel.

A: ¹ _____'s your surname?

B: My surname's Morris.

A: How do you ² _____ that?

B: M-O-R-R-I-S.

A: How ³ _____ are you?

B: I'm ⁴ _____.

4 ★★★  05 Posłuchaj nagrania i uzupełnij informacje o chłopcu.



- 1 Name and surname: _____
- _____
- 2 Age: _____
- _____
- 3 Locker number: _____
- _____

5 ★★★ Uzupełnij rozmowę Jade z Theo.



 Theo: Hello Jade. ¹ _____ ?

 Jade: It's ² _____.

 Theo: How ³ _____ ?

 Jade: S-T-E-W-A-R-T.

 Theo: ⁴ _____ ?

 Jade: ⁵ _____ twelve.

 Theo: ⁶ _____ your locker number?

 Jade: ⁷ _____.



Quiz – Languages and alphabets

1 Rozwiąż kwiz o alfabetach. Napisz C (*Chinese*), H (*Hawaiian*) lub E (*English*).

- 1 It's a very short alphabet. _____
- 2 It has over 4,000 symbols. _____
- 3 There are 5 vowels in this alphabet. _____
- 4 It is beautiful but difficult to read. _____
- 5 It is easy to read but difficult to say. _____

2 Przeczytaj teksty o trzech alfabetach. Dopasuj do nich właściwe ilustracje.

1 **Ersu Shaba** Picture
The Ersu Shaba alphabet is from Tibet. It uses small pictures called *pictograms*. There are more than 200 different pictograms. It also uses different colours. The colours are very important because they can change the meaning.

2 **Braille** Picture
Braille is a special alphabet for blind people. The letters are raised dots on a page. Blind people touch the dots. Many blind people also use special computers and apps that read out texts in Braille.

3 **Katakana** Picture
In Japan, there is a special alphabet for foreign words. It's called *katakana*. There are 48 symbols in *katakana*. Japanese words use a different alphabet.

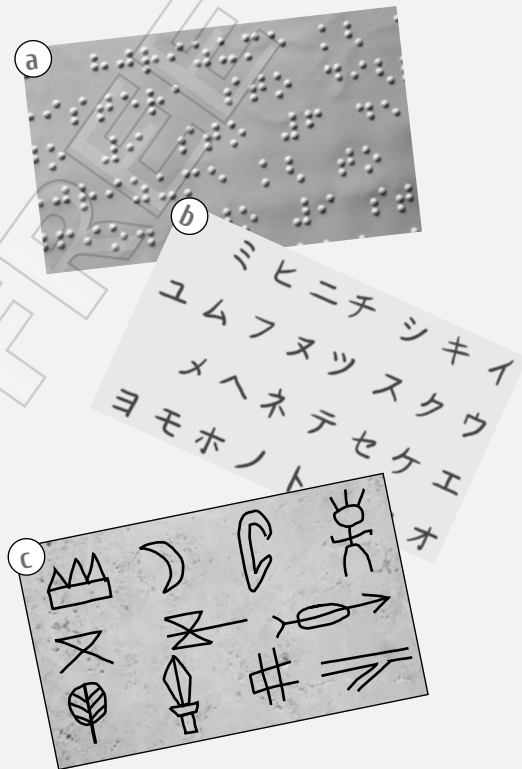

Glossary

meaning – znaczenie
 blind – niewidomy
 raised dots – wypukłe punkty
 foreign – obcy

3 Przeczytaj ponownie teksty z ćwiczenia 2. i odpowiedz na pytania. Napisz E (*Ersu Shaba*), B (*Braille*) lub K (*Katakana*).

- Which alphabet:
- is for foreign words? _____ K _____
 - 1 is from Tibet? _____
 - 2 is for blind people? _____
 - 3 uses different colours? _____
 - 4 has got 48 symbols? _____
 - 5 uses raised dots? _____

Life skills: Learning

Wymyśl trzy sposoby, dzięki którym łatwiej zapamiętasz nowo poznany alfabet.

- 1 _____
- 2 _____
- 3 _____

Vocabulary & Speaking

1 ★ Wykonaj działania matematyczne. Zapisz liczby słownie.

25 - 15 = ?

twenty-five - fifteen = ten

1 32 x 2 = ?

_____ x _____ = _____

2 4 + 53 =

_____ + _____ = _____

3 100 - 60 = ?

_____ - _____ = _____

4 74 + 8 = ?

_____ + _____ = _____

5 11 x 2 = ?

_____ x _____ = _____

2 ★★ Znajdź w diagramie nazwy ośmiu przedmiotów. Następnie podpisz zdjęcia.

| | | | | | | | |
|---|---|---|---|---|---|---|---|
| C | S | L | A | S | O | B | J |
| E | C | H | A | I | R | A | T |
| C | H | L | C | R | L | P | E |
| C | O | M | P | U | T | E | R |
| N | O | T | E | B | O | O | K |
| T | L | I | N | B | E | T | A |
| S | B | C | D | E | S | K | C |
| P | A | N | A | R | S | O | H |
| E | G | B | O | A | R | D | P |

1



2



3



4



5



6



7



8



3 ★★★ Uzupełnij dialog brakującymi wyrazami oraz informacjami z ramki.

Name: Alfie Mansfield

Age: 9 Locker: 72

Ella: ¹ _____ name?Alfie: My name's ² _____.Ella: What's ³ _____?Alfie: My surname's ⁴ _____.Ella: How ⁵ _____

_____?

Alfie: M-A-N-S-F-I-E-L-D.

Ella: ⁶ _____ locker number?Alfie: It's ⁷ _____.

Grammar

4 ★★ Uzupełnij zdania, wpisując *a*, *an* lub *-*.She is a student.

1 They are _____ teachers.

2 It is _____ desk.

3 They are _____ chairs.

4 It is _____ amazing invention.

5 He is _____ inventor.

5 ★★★ Ułóż z podanych wyrazów zdania.

Dodaj właściwe formy czasownika *be*. Jeśli to możliwe, użyj form skróconych oraz dodaj przedimki: *a* lub *an*.

We / inventors / . We're inventors .

1 It / orange / notebook / .

2 They / beautiful / green / schoolbags / .

3 I / Bella / .

4 You / my friend / .

5 My dog / ten / .

6 Joe and I / students / .

7 It / very / small / desk / .



Before you watch

- 1 Podpisz zdjęcia, uzupełniając wyrażenia słowami z ramki. Zaznacz (✓) nazwy zajęć, na które chciałbyś/chciałabyś chodzić.

roller hockey ■ rugby ■ drum
pottery ■ robotics ■ dance



_____ club



_____ class



_____ club



_____ club



_____ class



_____ class

While you watch

- 2 Obejrzyj film i sprawdź swoje odpowiedzi w ćwiczeniu 1., a następnie zaznacz właściwą odpowiedź na poniższe pytanie.

What's Mark's favourite activity?

- A making pottery
B playing the drums
C doing ballet

- 3 Obejrzyj film ponownie i zdecyduj, czy zdania 1-5 są prawdziwe (T = True), czy fałszywe (F = False). Zakreśl T lub F.

- 1 The robots can talk. T / F
2 Pottery is creative. T / F
3 Roller hockey isn't very fast. T / F
4 Rugby is only for boys. T / F
5 The boy is very good at the drums. T / F



Glossary

beautiful – piękny favourite – ulubiony
exciting – ekscytujący slow – wolny
fast – szybki

After you watch

- 4 Przeczytaj tekst o Alfiiem, a następnie uzupełnij drugi tekst informacjami o sobie. Narysuj swój portret lub wklej swoje zdjęcie.

AFTER SCHOOL

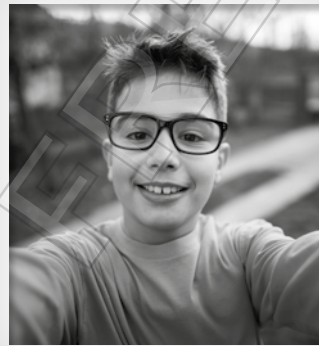

Hi,
My name's Alfie.
I'm 10 years old.
I love to do cool things after classes.
My favourite class after school is pottery class. I like pottery because it is creative and fun.

Hi everyone,
My name's _____.
I'm _____ years old. I like to do cool things after school.

I think my favourite activity after classes is _____. I like _____ because it is _____ and _____.



Life skills

- 5 Dokończ poniższe zdanie. Możesz skorzystać z Internetu, żeby znaleźć nazwy zajęć pozalekcyjnych, w których chciałbyś/chciałabyś wziąć udział.

It's important to try new activities.

This year, I want to try _____ and _____.

1 Uzupełnij wypowiedzi. Wybierz A lub B.

1 One night the sea is rough.

- 1 A What's wrong?
- B How are you?

4 It is 4th May, 1699. The Antelope is going to the Far East.

- 4 A My name's Lemuel Gulliver.
- B What's your name?

2 There are hundreds of little men. They have got bows and arrows. They speak a strange language.

- 2 A I don't understand.
- B I'm happy.

3 There is something on Gulliver's hand. It is moving up his arm.

Gulliver opens his eyes. He sees a very little man.

5 Where am I? What's wrong? I can't move my arms! I can't move my head!

- 3 A How old are you?
- B What's that?
- 5 A I can swim.
- B I can't move my legs!



Glossary

- | | |
|-----------------|---------------|
| arrow – strzała | ship – statek |
| bow – łuk | storm – burza |
| sea – morze | |

2 Ułóż obrazki zgodnie z kolejnością wydarzeń.

3 Połącz wyrazy i wyrażenia 1-4 ze znaczeniami A-D.

- | | |
|-------------------------------|------------------------|
| 1 rough | A rozumieć |
| 2 understand | B podróżowanie |
| 3 to speak a strange language | C wzburzone |
| 4 travelling | D mówić w obcym języku |

4 Zdecyduj, czy zdania 1-4 są prawdziwe (T = True), czy fałszywe (F = False). Zakreśl T lub F.

- 1 Lemuel Gulliver is the captain of the ship. T / F
- 2 The sea is dangerous at night. T / F
- 3 The little man is Gulliver's friend. T / F
- 4 Gulliver can speak the little people's language. T / F

5 W parach wymyślcie i opowiedzcie sobie dalszy ciąg historii.